

# How to Make a Tool Roll

Once you have sharp tools, it is worth protecting the edges as much as possible by storing or transporting them in a tool roll. This pattern is designed for 20 chisels and gouges. It is easy to increase or decrease the size, but I do not think I would go above 30 in one roll. The roll would become awkward to handle. Traditionally tool rolls were made of green baize, but burlap or canvas will do very well.

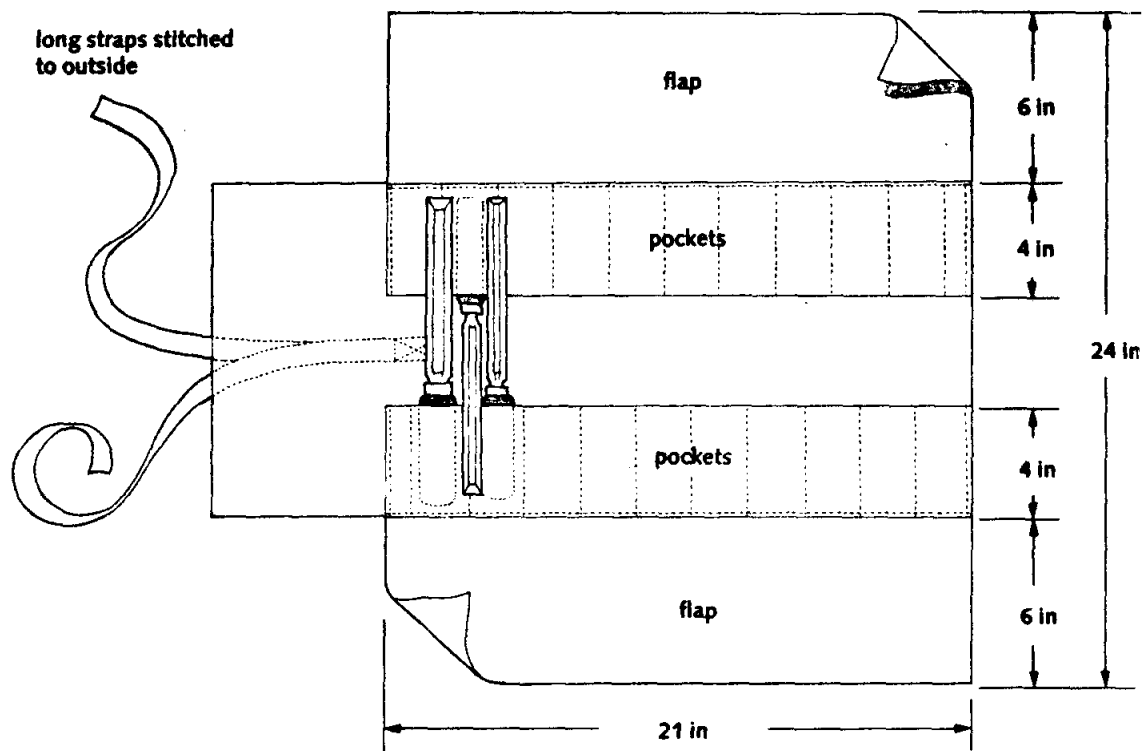

*Tool Roll Pattern*

Pockets for the tool handles are staggered so that the edge of tool on one side lies between two handles of the tools opposite. The side flaps not only protect the edges, but stop tools from sliding out. Two straps and the end flap keep it all together when it is rolled up.

Mountain Star Studio's Carving Bench

Roanoke, Virginia

E-Mail: [VACARVER@JUNO.com](mailto:VACARVER@JUNO.com)

URL: [members.tripod.com/TheCarvingBench](http://members.tripod.com/TheCarvingBench)